

# 142185-000 JWL Cooling System Flusher



## JWL Cooling System Flusher Quick & efficient cooling system flushing

Ensure optimum cooling system operation with the JWL Cooling System Flusher. Engine coolant degrades over time and most likely contaminates with abrasive particles and foreign materials.

Prevent this from happening by flushing the cooling system occasionally and when replacing cooling system parts. JWL Cooling System Flusher works without the use of solvents or harsh chemicals.

The JWL Cooling System Flusher combines water with compressed air to increase the efficiency of the cooling system flushing. The compressed air increases the water pressure compared to the one delivered from the main water supply.

The JWL Cooling System Flusher is equipped with an  $\varnothing 13$  mm,  $\frac{1}{2}$ " connection for water couplings. We recommend the use of a Hose Connector with a Control Valve. This saves you a trip to the tap to adjust or switch off the water flow.

Insert the stepped gun nozzle of the JWL Cooling System Flusher into the hose suited for the flush job and flush as much as needed until the radiator/engine block/heater core outflow is clear. With water flowing through the system, give short intermittent blasts of air to increase the efficiency. Make sure there is free passage through the cooling system you are flushing to prevent damage.

The materials used for the JWL Cooling System Flusher are impact resistant.

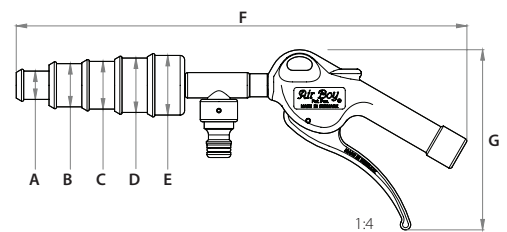

### Dimensions

A	$\varnothing 19$ mm	C	$\varnothing 32$ mm	E	$\varnothing 40$ mm	G	120.9 mm
B	$\varnothing 29$ mm	D	$\varnothing 36.5$ mm	F	302.4 mm		$\frac{1}{4}$ " BSP

Materials		Specifications	
Handle and trigger	Acetal plastic	Working pressure	6 - 10 Bar (87 - 145 psi)
Valve	Acetal plastic	Air consumption	350 l/min at 8 bar
Gaskets/O-rings	Nitrile	Weight	~0.230 kg
Nozzle	POM	Water consumption	6 l/min
Spring	Hardened spring wire	Water connection	$\frac{1}{2}$ " Nipple for water coupling
		Air connection	$\frac{1}{4}$ " internal thread (BSP)

# 142185-000 JWL Cooling System Flusher



## Draining the old coolant

### 1. Safety first

Always wait until the engine is cool before working on any part of the cooling system.

**2. Press down on the radiator cap (A), slowly turn it counter-clockwise until it hisses, wait until the hissing stops and then remove the cap**

**3. Place a large container under the drain valve (B) at the bottom of the radiator**

Check the vehicle service manual to locate all of the coolant drain valves in the engine block and cooling system.

**4. Loosen the drain valve (B) and allow the coolant to completely drain out**

If the radiator does not have a drain valve, disconnect the lower radiator hose (C) and allow the coolant to drain out.

If the vehicle is equipped with an individual expansion tank (D), disconnect all hoses connecting it to the cooling circuit and allow the coolant to drain out.

**5. Think about the environment and properly dispose of the old coolant**

## Flushing the system

**6. Read these user instructions completely before you begin and follow them carefully**

**7. Prepare the vehicle for the flush**  
**Radiator:** remove lower radiator hose (C), upper radiator hose (E), and if possible, completely remove the drain valve (B) to allow for debris outflow from the lowest point of the radiator.

**Engine block:** remove lower radiator hose (C), upper radiator hose (E) and thermostat (F).

**Heater core:** the heater control valve (G) must be verified to be open before attempting to flush through the valve. If this cannot be verified then it should be removed.

**8. Insert the stepped gun nozzle of the JWL Cooling System Flusher into the hose suited for the flush job and flush as much as needed until the radiator/engine block/heater core outflow is clear. With water flowing through the system, give short intermittent blasts of air to increase the efficiency.**

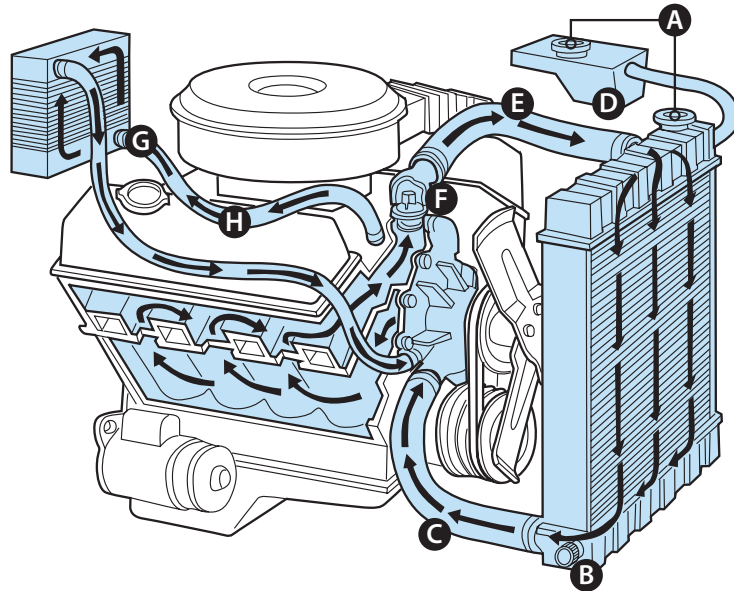

**Radiator:** Due to the larger chambers in the radiator, flooding the radiator first allows for kinetic waves to travel through the water and clear debris more effectively. Flood the bottom of the radiator. With the radiator cap on flush from the bottom up first. After a minute or two finish by flushing the system from the neck down

**Heater core:** connect the JWL Cooling System Flusher to the inlet heater hose (H) and start flushing. Make sure the heater control valve (G) is open or removed as earlier described.

**Engine block:** connect the JWL Cooling System Flusher to the upper radiator hose (E) and collect the water from the lower radiator hose (C).

**9. Inspect the coolant hoses, thermostat and water pump and replace them if necessary**

## Refilling the system

**10. Retighten the drain valve at the bottom of the radiator**

Make sure all the hoses are properly reconnected.

**11. Refill the cooling system with the correct vehicle manufacturer's recommended coolant, ensuring that the cooling system is bled following vehicle manufacturer instructions**

The moment the cooling system is drained, air replaces the coolant. When the system is refilled, air can get trapped in the cooling circuit. Air in the system is to be avoided at all times. Air bubbles considerably reduce the circulation of the coolant and may lead to engine overheating. They also accelerate the rust process, shortening the life of the system. Some systems are equipped with a bleeding valve on the upper radiator hose that allows trapped air to escape from the system. Other systems require that the expansion tank is dismounted/pulled upwards to vent the trapped air. Therefore, JWL recommends to always check the vehicle service manual for the prescribed bleeding procedure.

**12. Inspect the radiator cap (A) and expansion tank cap (A) (if applicable) and replace them if necessary**

**13. With the engine at operating temperature, recheck the coolant level and top up after engine cool down if required**

**14. Do a final visual inspection to ensure there are no leaks**  
Keep in mind that some leaks will become obvious when the engine is cold, but others only when it is hot.

**CAUTION**  
Extreme care should be taken when flushing Cooling Systems in poor condition.

